

# POWER LINE CHOKE



## Common Mode Chokes

- \* High Resonance Frequency.
- \* High Pulse Strength.
- \* Excellent Mechanical Strength.
- \* DC/DC, AC/DC Line Noise Suppression.
- \* Low Resistance and Temperature Rise.
- \* Design complies with EN 60938-2 (VDE 0565-2)

### ELECTRICAL SPECIFICATIONS AT 25°C - OPERATING TEMPERATURE RANGE -40°C TO +130°C

PART NUMBER		INDUCTANCE @ 10KHz (mH -30%,+40%)	CURRENT Arms @50C	DCR TYP (mOhms)
VERTICAL	HORIZONTAL			
LFV-20330	LFH-20330	33.0	0.3	1780
LFV-20180	LFH-20180	18.0	0.5	725
LFV-20056	LFH-20056	5.6	0.8	245
LFV-20039	LFH-20039	3.9	1.0	170
LFV-20033	LFH-20033	3.3	1.2	125
LFV-20018	LFH-20018	1.8	1.5	75
LFV-20008	LFH-20008	0.8	2.0	38
LFV-24440	LFH-24440	44.0	0.5	1250
LFV-24180	LFH-24180	18.0	0.8	440
LFV-24100	LFH-24100	10.0	1.0	244
LFV-24045	LFH-24045	4.5	1.5	115
LFV-24025	LFH-24025	2.5	2.0	65
LFV-24012	LFH-24012	1.2	3.0	30
LFV-24005	LFH-24005	0.5	4.0	15
LFV-28750	LFH-28750	75.0	1.0	880
LFV-28360	LFH-28360	36.0	1.0	590
LFV-28270	LFH-28270	27.0	1.5	280
LFV-28200	LFH-28200	20.0	1.5	280
LFV-28150	LFH-28150	15.0	2.0	195
LFV-28110	LFH-28110	11.0	2.0	160
LFV-28090	LFH-28090	9.0	3.0	115
LFV-28050	LFH-28050	5.0	3.0	80
LFV-28035	LFH-28035	3.5	4.0	50
LFV-28023	LFH-28023	2.3	4.0	40
LFV-28011	LFH-28011	1.1	5.0	28

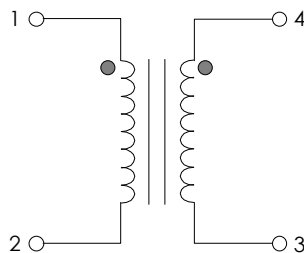

**RoHS**

# POWER LINE CHOKE

## Common Mode Chokes



**LFV20**

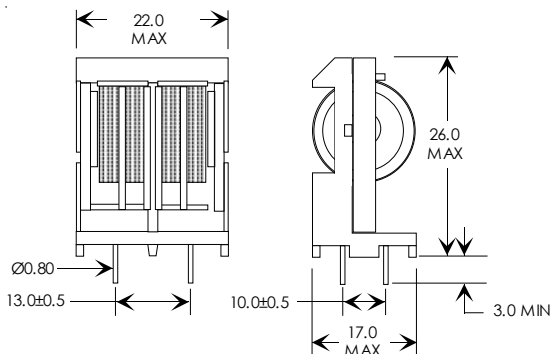

**LFH20**

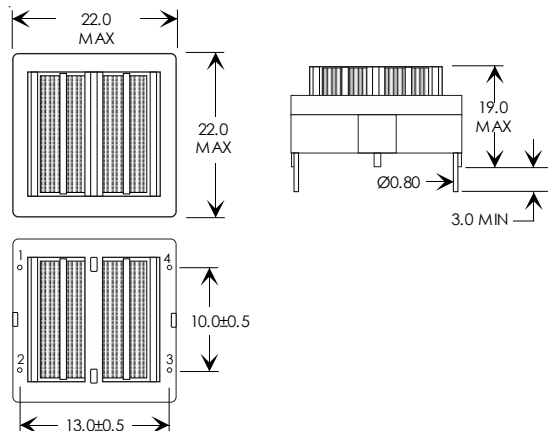

**LFV24**

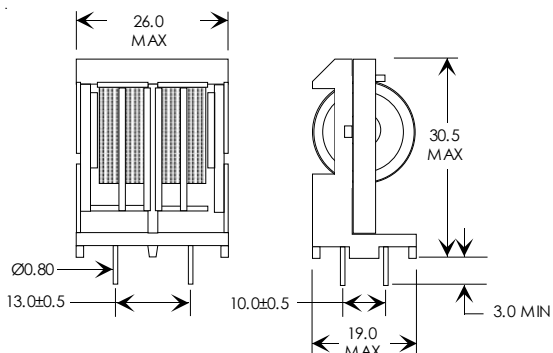

**LFH24**

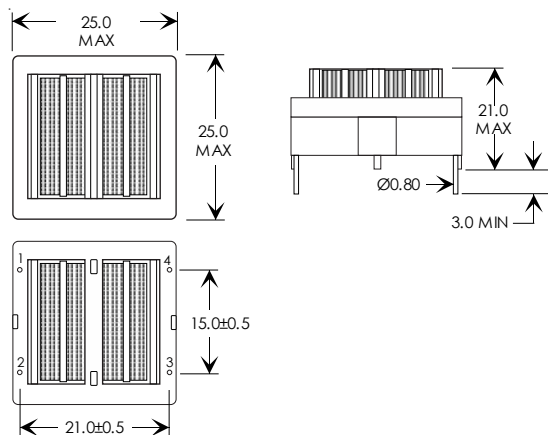

**LFV28**

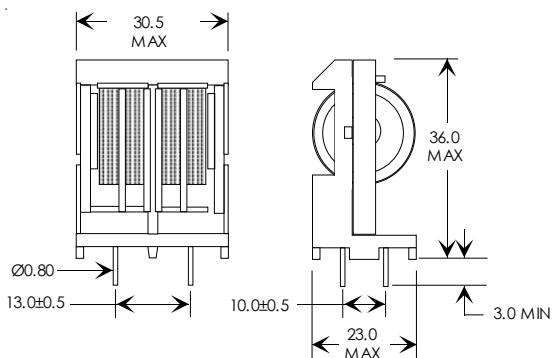

**LFH28**

