

# OFF-LINE SWITCH MODE TRANSFORMERS

- o Designed for use with Power Integrations, Inc. TOPSwitch-HX switch mode power supply Controller Family.
- o Designed to meet UL/IEC 60950 Safety Standards.
- o Multiple configurations.
- o Designed to meet Class B insulation.
- o Design Engineering Support Available.

## GENERAL APPLICATION INFORMATION

The Premier Magnetics, Inc.'s POL-HXxxx line of Transformers listed in this brochure are designed specifically for use with Power Integrations, Inc. HX series lineup of switcher controllers, and together in the design of their standard off-line AC-DC flyback power supplies. This conversion topology can accept universal 90-265 VAC input and deliver single and multiple isolated outputs with high efficiencies under all load conditions.

The Power Integrations' TOPxxxEN series controllers as noted in the table on the second page of this document operate at a higher frequency of 132kHz or, as an option, at the half frequency of 66kHz. The higher 132kHz frequency allows for a smaller physical Transformer which in turn results in a smaller overall power supply size. There is an optional lower 66kHz frequency available on these "EN" series controllers for video applications. The other non-"EN" series controllers listed within the table operate at 66kHz only.

This POL-HXxxx series of Premier Magnetics, Inc. Transformers are designed to provide high performance and reliability, high efficiency across the load, and maximum power throughput, providing value to support a cost effective power supply design.

## APPLICATION CIRCUIT

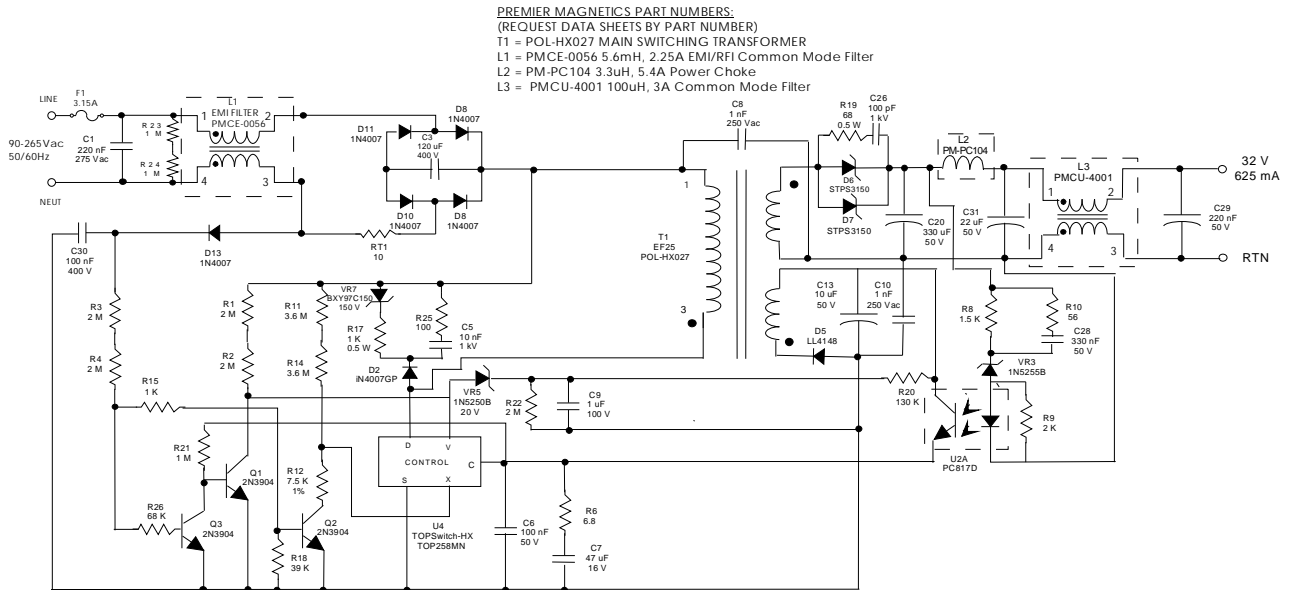

Note: The above application circuit is that of a 20W continuous, 80W peak, universal input power supply using the Power Integrations, Inc.'s TOPSwitch-HX Controller TOP258MN, and the Premier Magnetics, Inc.'s isolation Transformer POL-HX027, Common Mode Choke PMCE-0056, and Power Inductor PM-PC104.

